

ECO AID CHAMBERS FOR UNDERGROUND STORMWATER MANAGEMENT



DETENTION / RETENTION / INFILTRATION / HARVESTING

with sediment +
gross-pollutant removal



**100% AUSTRALIAN
DESIGNED
MADE & OWNED**

TYPICAL CROSS SECTION

300mm sub-base material. Compact in 2 lifts to 95% Standard Proctor density, (eg Class 1 or 2 crushed rock RCC)

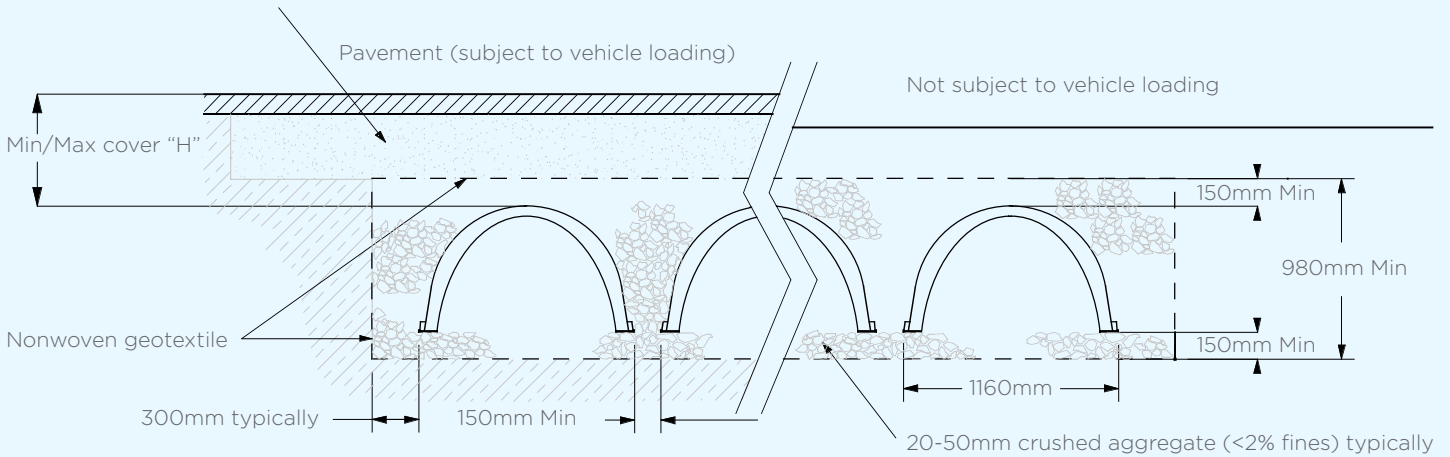

(NOT TO SCALE)

LOCATION	Hmin*	Hmax
Not subject to vehicle loading	300mm	2500mm
Subject to vehicle loading		
Not in roadway	450mm	2500mm
In sealed roadway	600mm	1800mm
Under unsealed roadway	750mm	1800mm
In embankment conditions	750mm	1800mm

*AS/NZS 2566.1:1998 subject to variation by local regulatory authorities.

KEY FEATURES OF THE SYSTEM

1. Corrugated Arch Design - incorporating a true parabolic inner profile for optimum load-shed via soil arching, with boxed-out (ie varying depth) corrugations for localised buckling resistance where it is needed most.
2. The flat, keyed feet of the arches become locked into place by the embedment aggregate preventing movement during backfill placement and compaction.
3. Integrated vertical and lateral pipe ports (ø100mm or ø150mm), eliminating the need for expensive header and manifold pipes external to the storage footprint to distribute the inflow between rows.
4. Articulated joint between arches allows chamber placement along a curve or radius (down to R = 25m)
5. Flat End Cap base design ensuring no rotation of end cap and chambers when backfill material is placed.

💧 Injection moulded from high quality, uniform virgin polymer resin, meeting roads authorities requirements for applications subject to vehicle loads and long term soil dead loads.

💧 Extensive product development & rigorous testing in Australia to the criteria of local roads and transportation agencies and AS/NZS standards, by NATA accredited testing bodies.

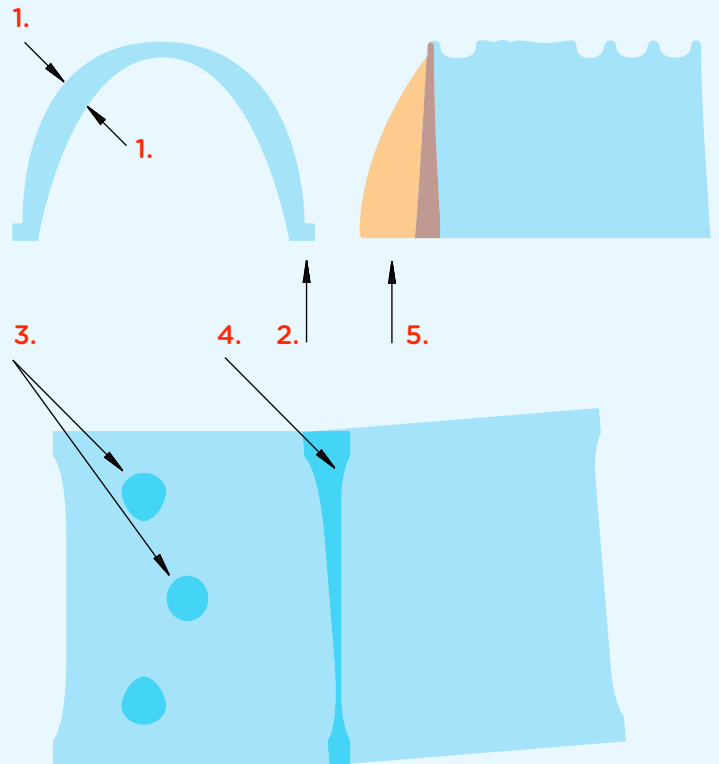

💧 Manufactured in Australia to ISO Quality Management System standards.

💧 The arch and end cap size and weight are optimised for safe lifting and rapid deployment by installation personnel.

TECHNICAL DATASHEET

ecoAID EC-1000 CHAMBER

Size (W × H × Installed L)
1160 mm × 680 mm × 1000 mm

Chamber Storage
516 litres / 0.516 m³ per arch

Min. Installed Storage
(p_s = 0.40) 822.4 litres /
0.822 m³ per arch (inc. stone)

Min. Installed Storage Height
980 mm

Weight
Arch - 15.0 kg[^]
End Cap - 5.0 kg[^]

Shipping
(Pallets-1.16 m × 1.14 m)
32 Arches + 4 End Caps
per pallet

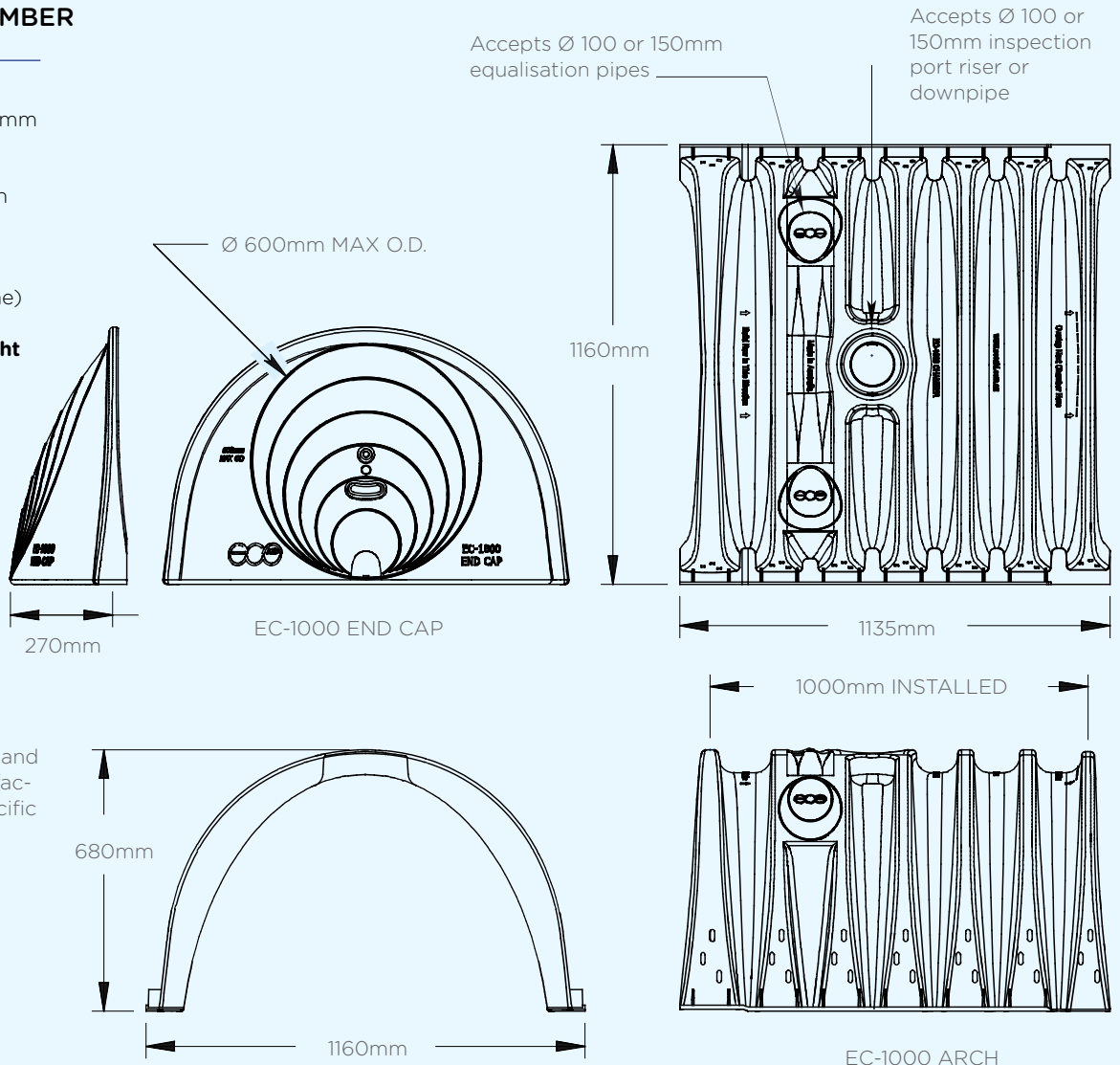

Note
[^] values are typical weights and are subject to +/- 3% manufacturing and raw material specific gravity variance.

(NOT TO SCALE)

OPTIMISE YOUR LAND USE MINIMISE YOUR CARBON FOOTPRINT!

EcoAID's modular approach to stormwater storage, along with our superior structural strength enables the optimal use of land available for development.

There is no need to avoid heavily trafficked areas, and the shape of the installation is completely flexible. EcoAID's articulated joints even allow for placement on radii as small as 25m, so the geographical contour of a site, or the curves of a road or roundabout can be followed.

With ecoAID chambers being completely buried, the expected service life will be typically 10 times that of above ground Poly tanks that are exposed to UV degradation. Therefore, the carbon footprint will be much smaller over the lifespan of the system. EcoAID chambers have a much smaller carbon footprint than concrete tanks and galvanised steel due to the energy intensive nature of fabrication of these materials, and with incredibly efficient stacking of arches for transportation the carbon miles are also minimised.



APPLICATIONS

DETENTION, INFILTRATION/RECHARGE

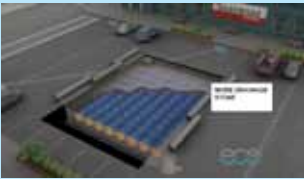
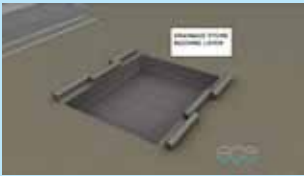

The shortfall of many modular stormwater detention and infiltration systems is their inability to address the sediment and solids that are transported in the stormwater during a rainfall event. When stormwater is transported by pipe into a larger storage it slows down, and depending on the reduction in velocity or detention time within the storage, much of the solid mass being carried by the stormwater will be deposited. EcoAID offers a simple and effective way to manage the solids entering the system.

TREATMENT

The environmental benefits of solids removal are well documented, however the more effective a system is at removing contaminants and solids the more often it will need to be cleaned - yes? Well, not necessarily. It also depends on the volume available for sedimentation and solids deposition.

EcoAID enables the designer to maximise this volume and minimise the maintenance return interval, so you spend less time and money cleaning it out! This is called a win / win situation!

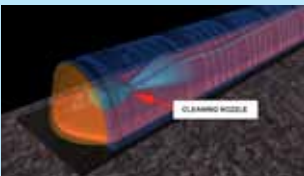

DETENTION

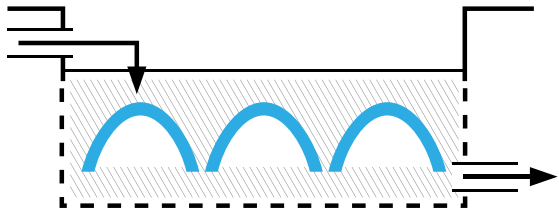

INFILTRATION / RECHARGE

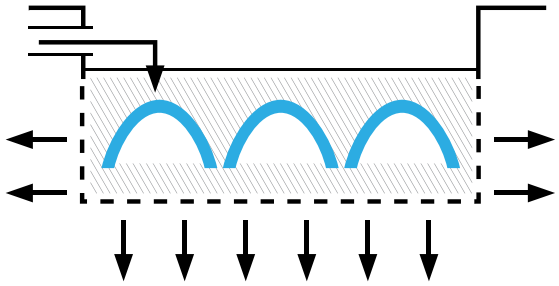

TREATMENT

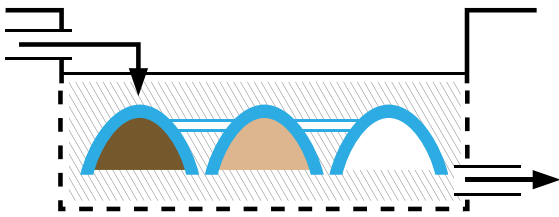

HARVESTING

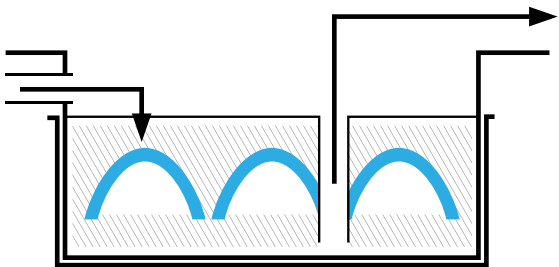

HARVESTING



EcoAID can be used to harvest rain and stormwater in much the same way that natural aquifers or perched groundwater can be accessed by bores. One major advantage is that we are creating and replenishing that resource from water captured off roofs and other hard surfaces, such as carparks and roads, as opposed to extracting from a natural aquifer that may have taken thousands of years to form, and cannot be replenished as easily.

In a natural aquifer water is purified through slow percolation and filtration. Similarly the EcoAID system is able to filter and treat captured water using a variety of natural or synthetic filter media.

Best of all, the system is not taking up additional land space being below ground, and is secure from vandalism, fire and theft, and not exposed to UV degradation or large temperature variations.



HARVESTING



ENVIRONMENTAL BENEFITS

LOW CARBON FOOTPRINT AND CARBON MILES

- The system is 100% recyclable and has been load tested with recycled crushed construction waste for the embedment media, potentially diverting many tonnes away from landfills.
- State-of-the-art manufacturing featuring low energy consumption, servo-hydraulic plant with energy savings between 20 and 80%.
- High energy consuming materials such as steel or concrete are not required for system strength.
- With EcoAID being manufactured in Australia, the 'carbon miles' are lower than imported systems. The stacking and transportation efficiency makes ecoAID chambers a sound environmental choice compared to oversize round pipe in detention and infiltration applications.

STORMWATER TREATMENT

- Sediment and gross pollutant management and removal capability, with longer maintenance intervals than stand-alone GPTs due to the large volume available for sediment and gross pollutant collection.

LONG SERVICE LIFE

- UV degradation is not a factor with the EcoAID system being buried. In stormwater harvesting applications the service life could be up to 10 times longer than above ground 'Poly' tanks that are exposed to UV.
- The storage is serviceable due to unimpeded access to the rows for cleaning and maintenance from the ground surface level, so storage volume is not lost over time.



EASY TRANSPORTATION AND HANDLING

- Rapid installation of the chambers due to optimisation of system size / maneuverability (by one person) versus storage capacity.
- Conformance to Australian and New Zealand Occupational Health and Safety recommendations for lifting by one person with system components weighing 15kg or less. (it has been shown that by keeping manual lifting weights to less than 16kg risk of injury is greatly reduced)
- Stacking efficiency on standard pallets ensure transportation costs are kept low, and installation is not slowed moving product around on site.
- With 30 arches per pallet (32 export) and the unit (installed) length 1.0m exactly, it is easy to place stacks at the required spacing to minimise manual handling.

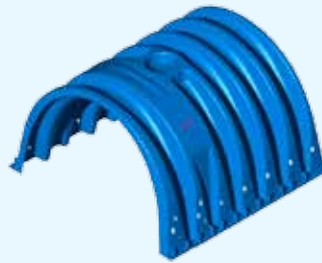

ARCH WEIGHT

15kg per single unit.



SUPERIOR STRUCTURAL PERFORMANCE

Ecoaid's superior structural strength allows end uses above the system such as high volume roads, car-parks, and specialised sporting surfaces. The structural integrity of the system has been rigorously assessed via full-scale field trials and a laboratory testing regime devised in consultation with Australian and New Zealand roads and transportation agencies and specialised pavement testing bodies. Australia and New Zealand build roads differently to other countries, with a high percentage of pavements having spray or 'chip' seal wearing courses, so testing and conformance to local criteria and standards is essential.

The EcoAID chamber system meets or exceeds the following essential criteria as stipulated by local transportation agencies:

- Load bearing capacity under static and dynamic design vehicle 'plate' loads. [AS 1597.1-1974, and VicRoads - Road Design Guidelines (Part 7 - Drainage)]
- Short and long-term allowable deflections. [AS/NZS 2566.1-1998]
- Manufacturing and Quality processes (MQC/MQA) to ISO/TS 16949 standards.



"If the system you have been specifying or using is not up to this standard please contact our sales or technical support department".



HIGH QUALITY TECHNICAL ASSISTANCE IS CLOSE AT HAND!

EcoAID is able to provide technical support to Design Engineers, Architects, Developers and Contractors. Information relating to application suitability, system sizing, design specifications / CAD, and installation training can be provided in DVD, electronic, or print format. Feel free to contact us or our distributors directly using the details provided below, or visit our website, where additional general and technical information is available. Which ever method you prefer, it's our goal to provide the highest level of technical assistance in a timely and professional manner.

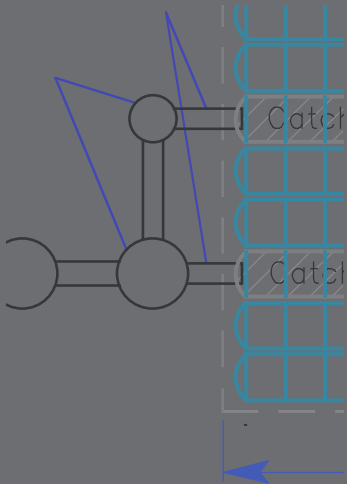
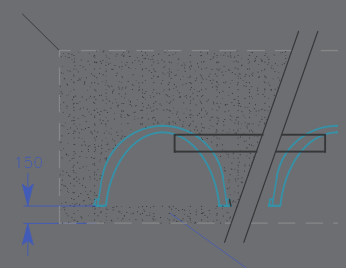
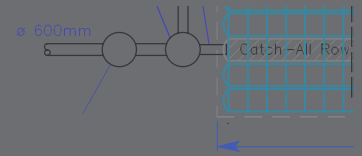

© Copyright.
All rights reserved.
EcoAID Pty Ltd, 2011.
—
Printed in Australia.

AUSTRALIA

—
ecoAID Pty Ltd
T / (61 3) 9940 1551
F / (61 3) 9381 0700

technical@
ecoaid.com.au

www.ecoaid.com.au

NEW ZEALAND

—
Maccaferri NZ
T / 0800 60 60 20
F / (64 9) 634 6492

technical@
maccaferri.co.nz

www.maccaferri.co.nz

